





**TINKERCAD** Começa por **aceder** a <https://www.tinkercad.com/> e **entra** na tua **conta criada** no **guião** anterior.

**TINKERCAD** **Cria** um novo projeto 3D.

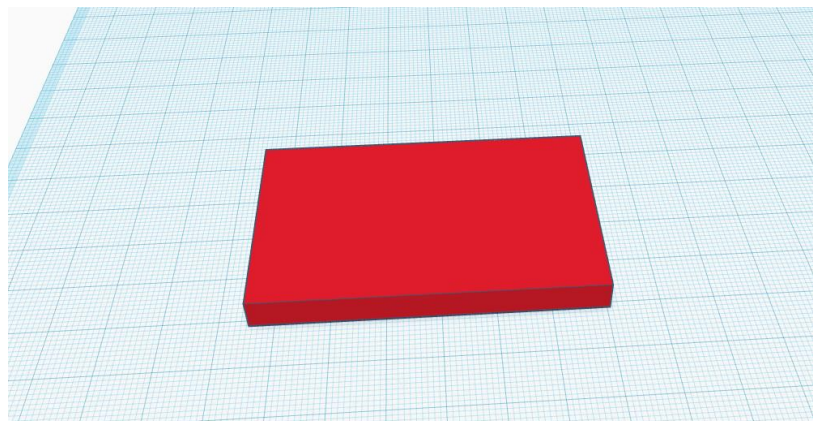

**TINKERCAD** **Insera** a forma caixa  e altera-a para as seguintes medidas:  
**X=65; Y=40; Z=6.**



**TINKERCAD** **Insera** outra caixa  muda-lhe a cor para verde  e altera-a para as seguintes medidas:  
**X=61; Y=36; Z=não alteres.**

Coloca essa caixa por cima da outra tal como mostra na figura:

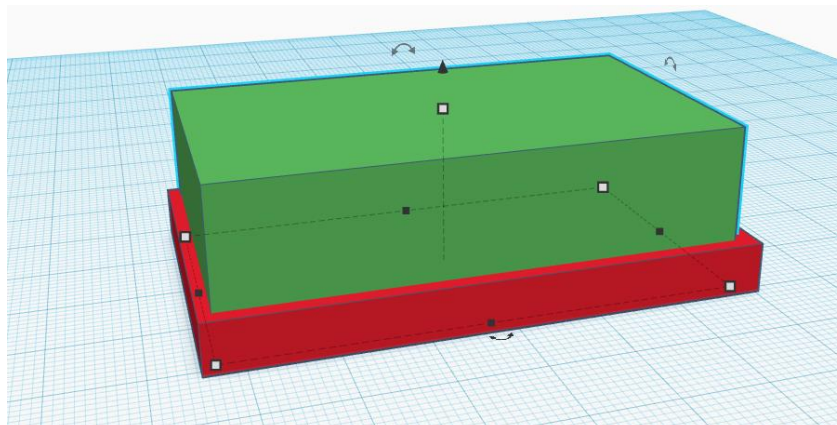



Seleciona as duas caixas e clica no menu superior direito em **Alinhar**. Vão surgir uns círculos pretos para ajudar a centrar uma forma na outra. Clica nos círculos ao centro da largura e do comprimento para a forma verde ficar no centro da forma vermelha.

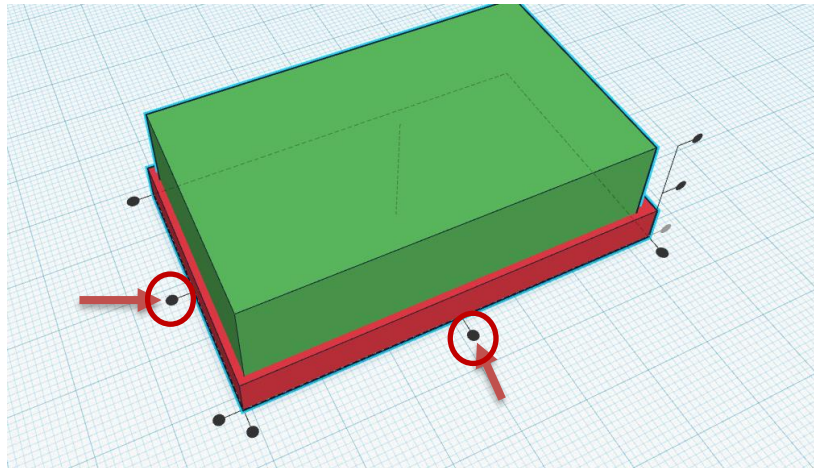
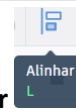

Clica de novo em **Alinhar** para desativar.



Agora que as formas estão centradas vamos retirar um pedaço da forma vermelha (fazer um buraco) usando a forma verde. Como queremos que fique tipo tabuleiro não vamos furar até baixo. Para isso começa por subir a forma verde até ao Z=2 de altura.

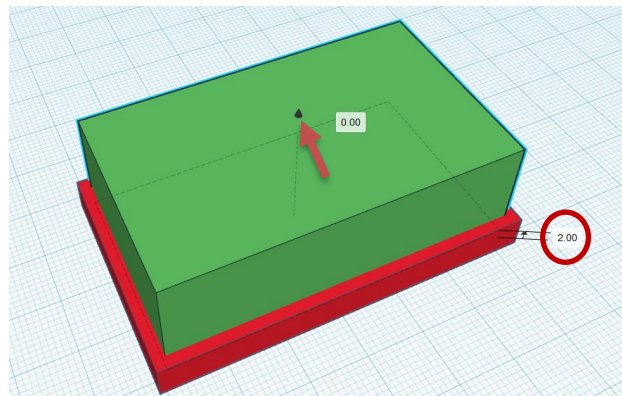

No menu superior direito escolhe a opção **Orifício** e ficarás com a seguinte forma.

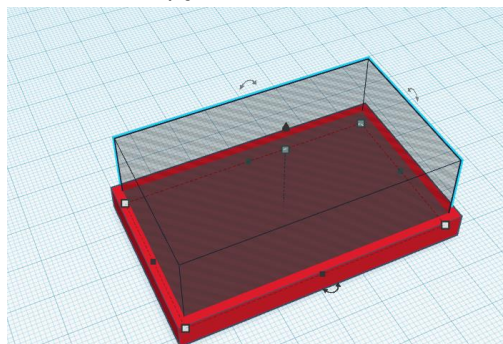



**T** **I** **N**  
**K** **E** **R**  
**C** **A** **D** Para **terminar** falta **voltar a seleccionar as duas formas** e no **menu superior** escolher a **opção**

 agrupar **Agrupar**  
**Ctrl + G**. Deverás obter a seguinte forma:

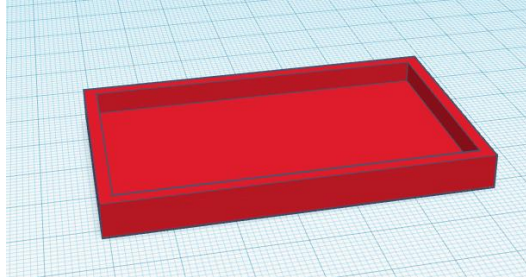

**T** **I** **N**  
**K** **E** **R**  
**C** **A** **D** Adiciona a forma **telhado arredondado**  e **gira-o** para que **fique com a meia lua para cima**:

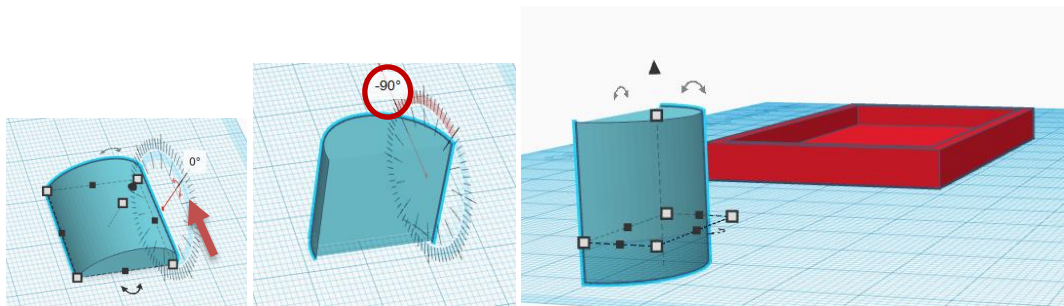

**T** **I** **N**  
**K** **E** **R**  
**C** **A** **D** **Sobe a forma** para que **não fique abaixo do plano de trabalho**:

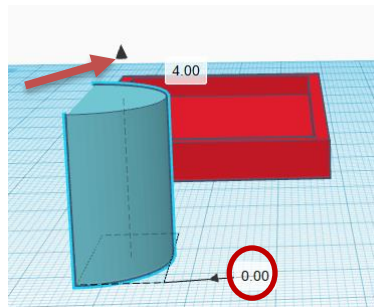

**T** **I** **N**  
**K** **E** **R**  
**C** **A** **D** **Ajusta a forma** para que **fique com as dimensões:**  
**X=6; Y=6; Z=6** e altera a **cor para a mesma do tabuleiro.**  
**Arrasta a forma para o canto superior esquerdo do tabuleiro.**

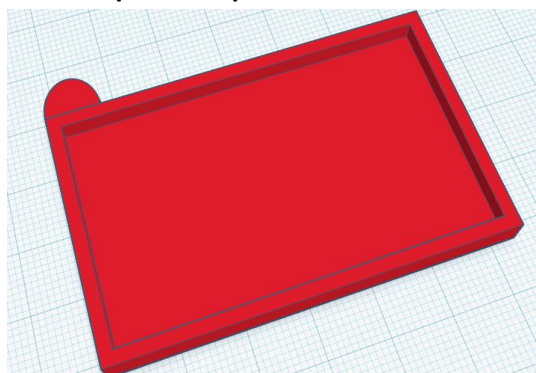



**TIN KERS CAD** Agrupa as duas formas para que se tornem uma só:

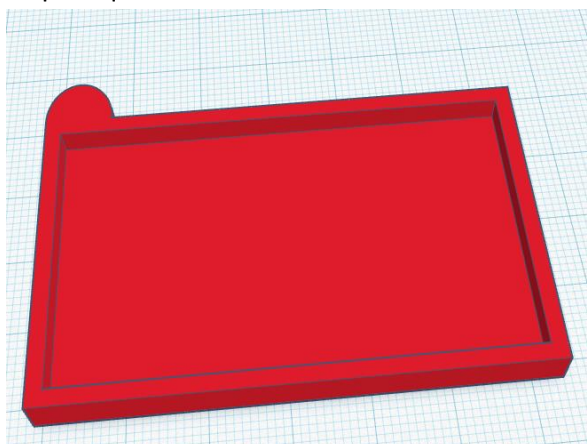

**TIN KERS CAD** Utiliza a forma cilindro para fazeres um buraco com 4 de diâmetro tal como mostra a figura seguinte.

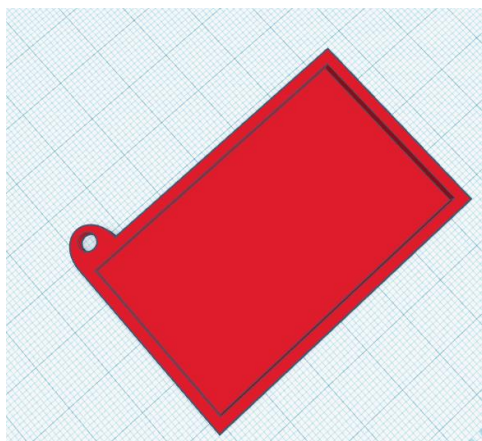

Atenção para conseguires centrar o buraco pode dar jeito desagrupar em certa altura. No



menu superior direito podes Desagrupar em qualquer momento.

**TIN KERS CAD** Finalmente introduz texto a dizer MS, centrado no tabuleiro e que fique nivelado pela parte superior do tabuleiro tal como mostram as figuras:

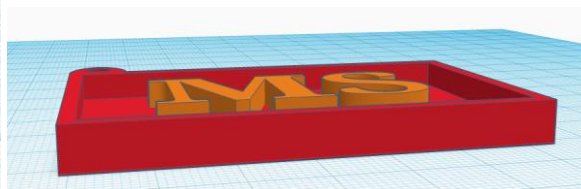

**TIN KERS CAD** Agora que sabes criar orifícios e juntar objetos altera a casa que criaste no 1º guião para que fique sem interior, com uma porta e uma janela. Vê o exemplo seguinte:



 **Chama o professor para avaliar os 2 trabalhos.**